

SECTION A-A TREE PIT (WITHOUT EXISTING RAILING)

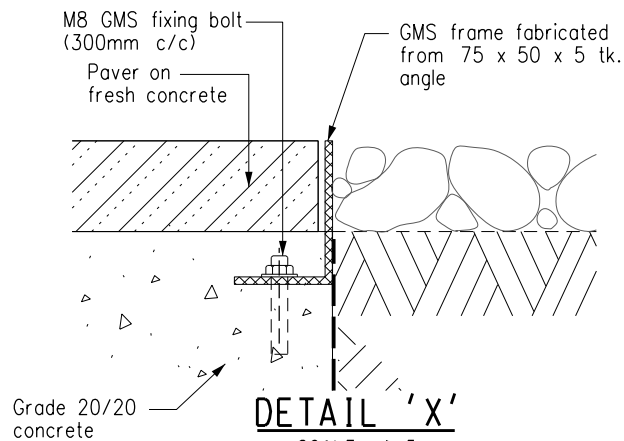

Notes:

1. All dimensions are in millimetre.
2. Tree pit planting is only considered as a last resort.
3. In new development area, sufficient and continuous greening zone should be designated for the tree planting and tree pit is not applicable for use. Kerb planter (Drawing No. H5146 or the latest version) should be used for roadside tree planting.
4. For re-development area, tree pits should be enlarged and joined together to form a kerb planter wherever practicable. Drawing No. H5146 or the latest version should be followed.
5. Tree guard to be installed where applicable and prior agreement should be sought from tree management department. Tree guard can be replaced by stakes if applicable. Tree guard/stakes to be removed when tree is well-established.
6. Tree species with aggressive root system and/or large root flare and/or large root buttress shall not be planted in tree pit except adequate space is available. Girdling and other defective roots shall be removed before planting.
7. Guidelines on Soil Volume for Urban Trees and prevailing technical circulars and guidelines promulgated by DEVB should be referred to for minimum soil provision of different desired tree sizes.

8. Sub-soil drainage should be duly considered and liaison with the relevant maintenance department should be taken during planning and construction stages as appropriate.
9. Reference should be made to DEVB's proper planting practices and relevant planting guidelines.
10. Reference should be made to dimensions as stipulated in DEVB TC(W) No. 3/2024 - Allocation of Space for Quality Greening along Roads or prevailing version & Guidelines on Soil Volume for Urban Trees.

A	General revision	Original signed	Mar 25
	New Issue supersedes H5141	Original signed	Oct 20
REF.	REVISION	SIGNATURE	DATE

**TREE PIT PLANTER
(SHEET 2 OF 2)**

HIGHWAYS DEPARTMENT

REFERENCE

DRAWING No.

CAD

SCALE

1 : 20 or
As Shown

H 5145A