

SECTIONAL SIDE ELEVATION

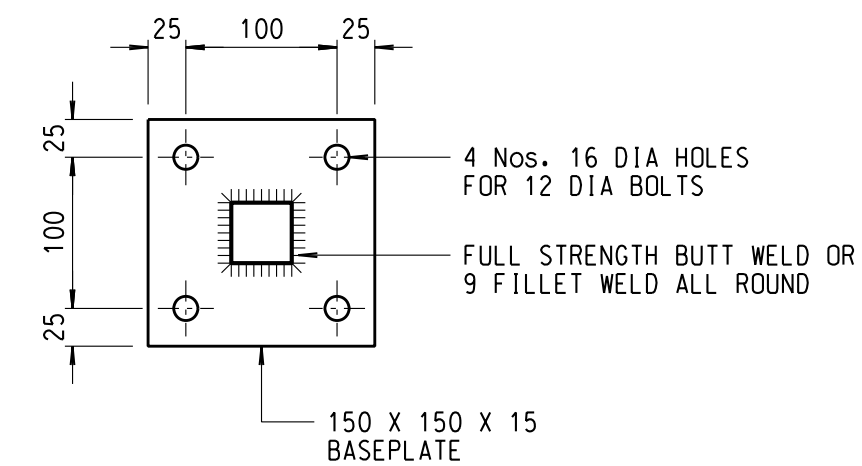

PLAN OF BASEPLATE

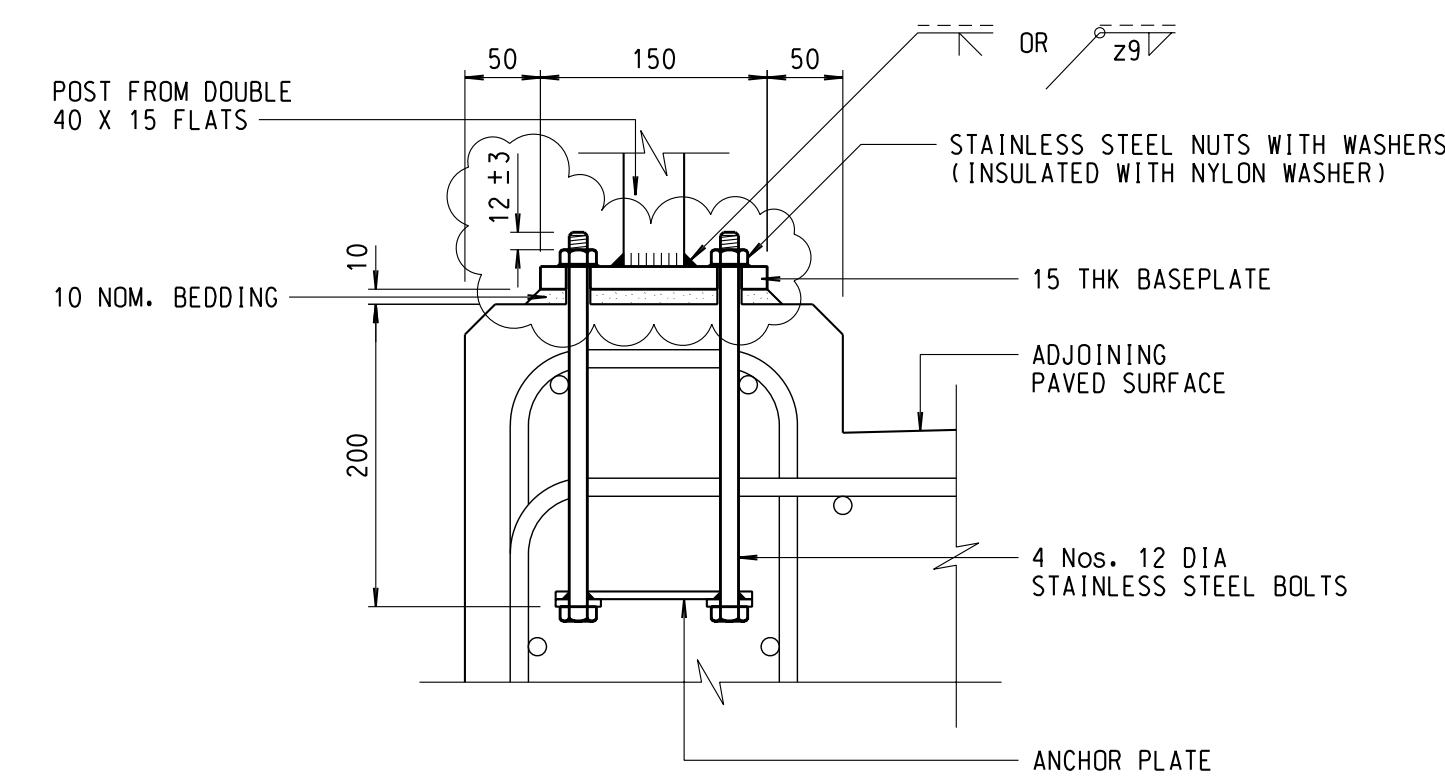

SECTIONAL SIDE ELEVATION

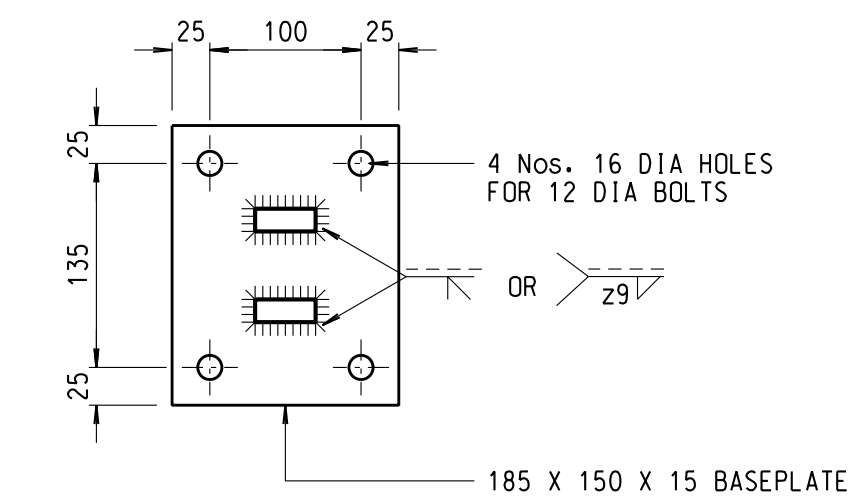

PLAN OF BASEPLATE

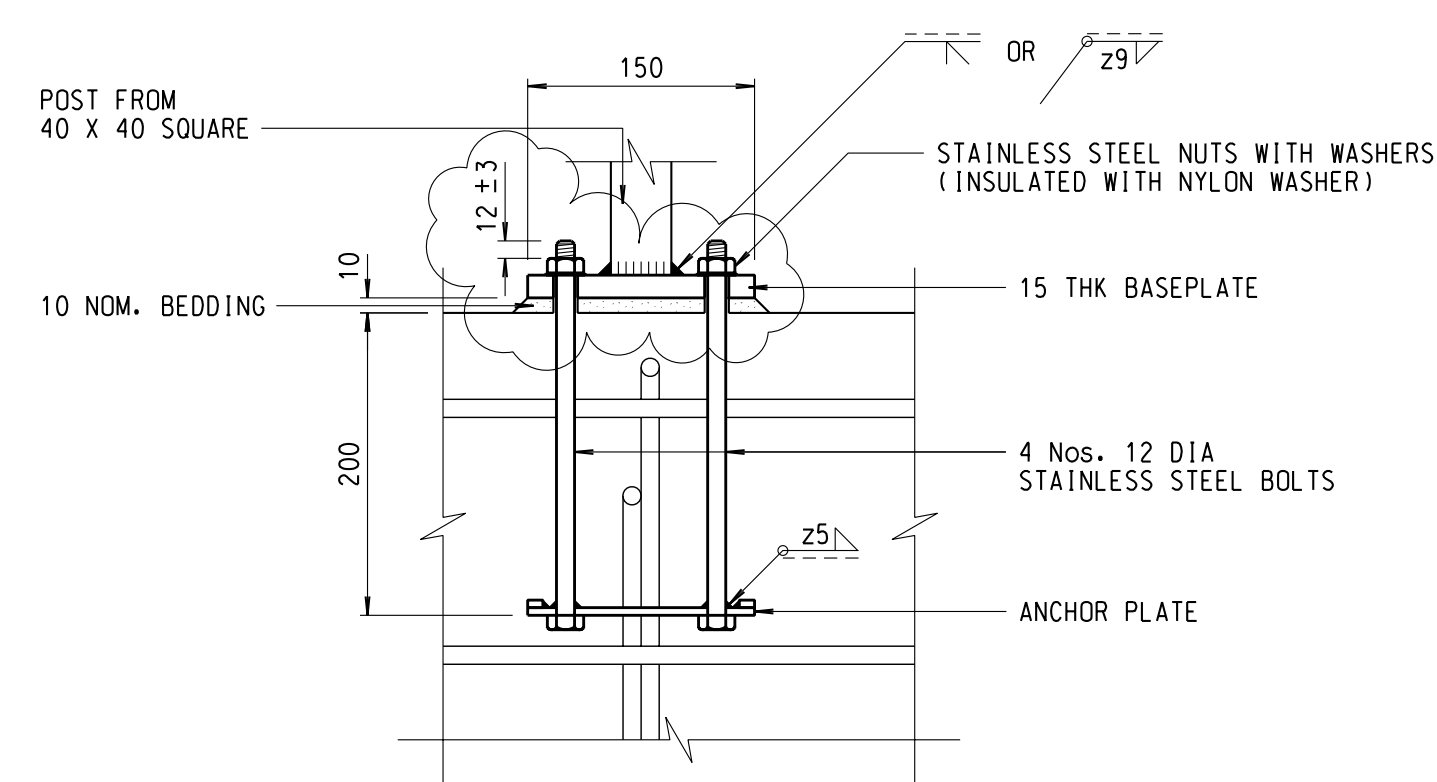

SECTIONAL FRONT ELEVATION

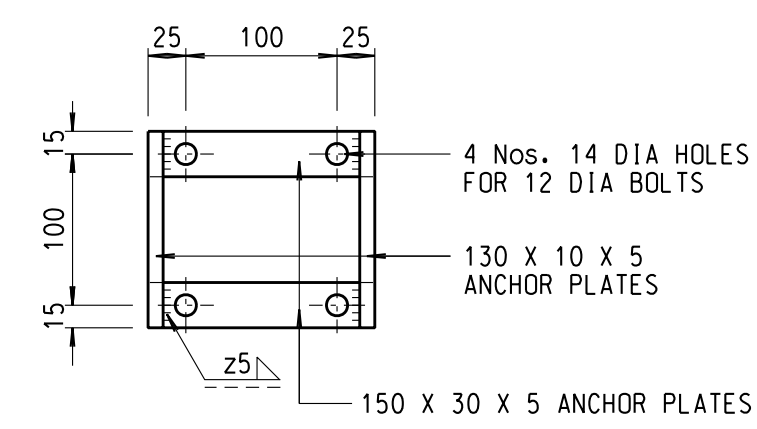

PLAN OF ANCHOR PLATES

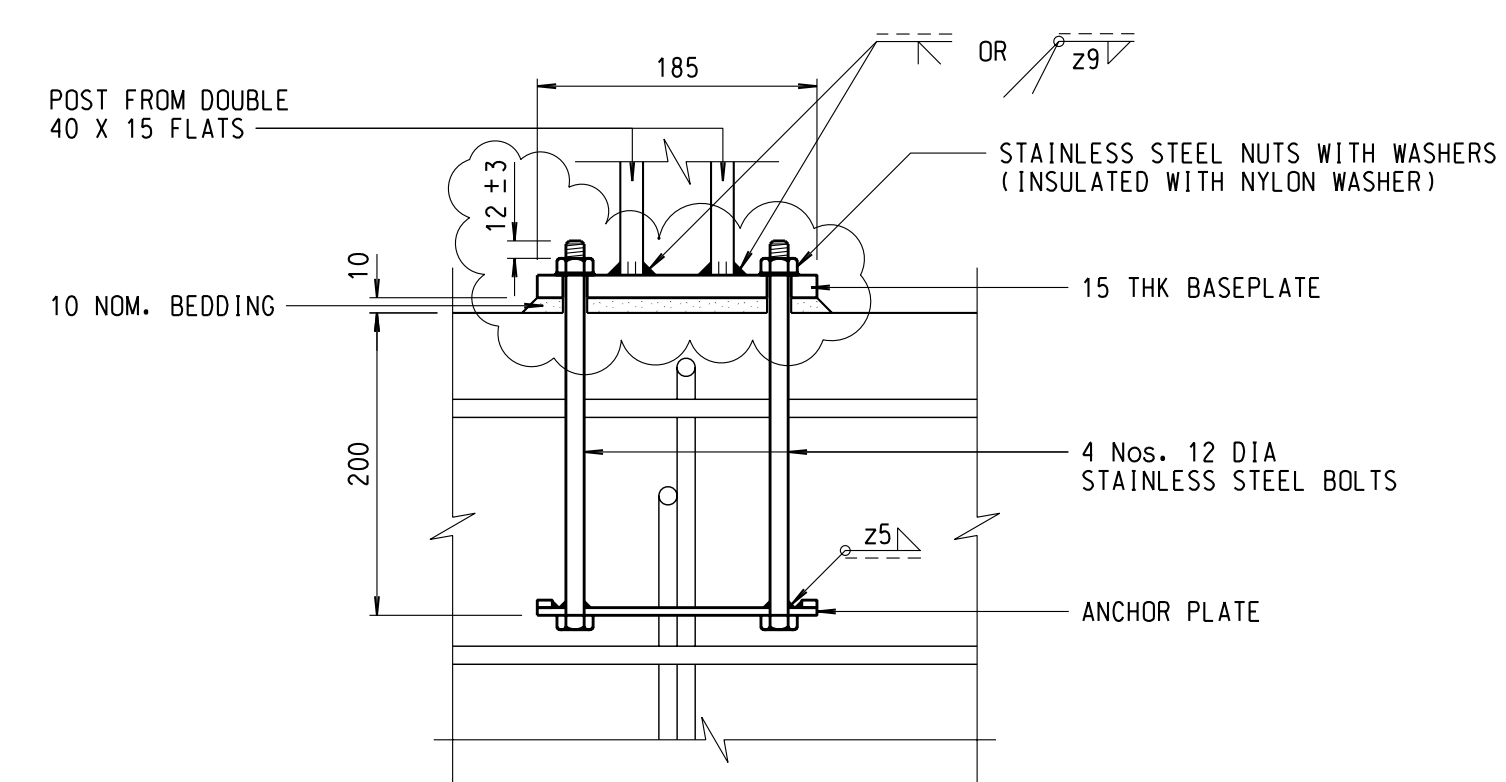

SECTIONAL FRONT ELEVATION

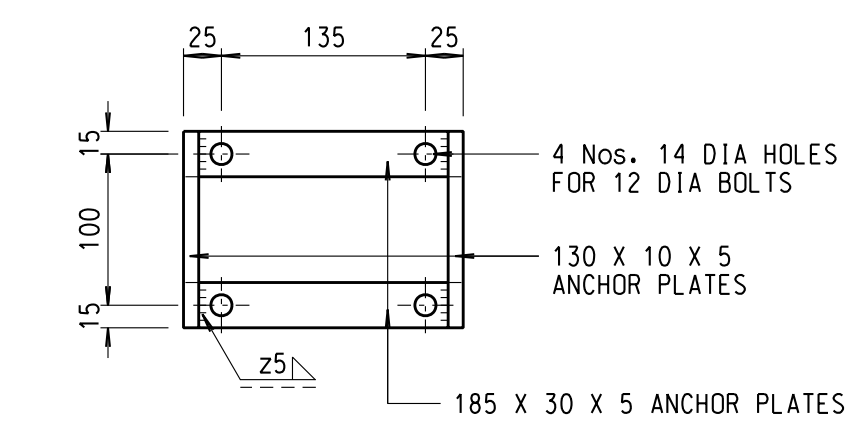

PLAN OF ANCHOR PLATES

BASEPLATE MOUNTING FOR 40 X 40 POST

BASEPLATE MOUNTING FOR 40 X 15 POST

NOTES:

1. ALL DIMENSIONS ARE IN MILLIMETRES.
2. STEEL IS TO BE GRADE 275J2H TO BS EN10210-1.
3. STEELWORK IS TO BE HOT-DIP GALVANISED TO BS EN 150 1461 AFTER FABRICATION.
4. WELDING IS TO BE IN ACCORDANCE WITH BS EN 1011 AND ELECTRODES ARE TO BE IN ACCORDANCE WITH BS 639.
5. ALL STAINLESS STEEL BOLTS, NUTS AND WASHERS SHALL BE OF GRADE A4-80 TO BS EN 150 3506 AND COMPLYING WITH BS 3692.
6. ALL STAINLESS STEEL FASTENERS SHALL BE INSULATED FROM THE GALVANISED STEELWORKS BY NYLON WASHERS OR OTHER INSULATING WASHERS APPROVED BY THE ENGINEER.

B	08/07	BASEPLATE AND BEDDING RAISED AND NOTES UPDATED	SIGNED M.K. LUI, AEE/PP
A	11/92	GENERAL REVISION	SIGNED R. TSUI
no.	date	description	initial

REVISION			
	name	signature	date
designed			
drawn	M. H. CHOI	SIGNED	NOV 92
checked			
senior technical officer / project engineer			
senior engineer	R. TSUI	SIGNED	NOV 92
approved			
		SIGNED	NOV 92
	K. W. WONG		date
	Chief Highway Engineer		

contract no.  
file no.  
project no.  
contract

drawing title  
**PEDESTRIAN PARAPET BASES**

drawing no. **SSD71-B** scale **1 : 5**

office **BRIDGES AND STRUCTURES DIVISION** 橋樑及結構部

**HIGHWAYS DEPARTMENT HONG KONG** 路政署 香港

**ORIGINAL SIGNED**

